

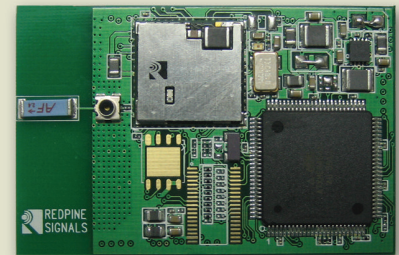

LOW-POWER METERING AND COMMUNICATIONS MODULE RS-SE-401

RS-SE-401 is a complete IEEE 802.11 b/gn Wi-Fi module for advanced water and gas meter applications. It is fully self-contained module with an ultra low power microcontroller, power management unit and built-in diversity antennas along with an option to connect external antennas. It supports high RF power output, very good receiver sensitivity and antenna diversity enabling long range wireless connectivity. It includes a DLMS standard-compliant meter server stack providing ease of integration into metering devices. When used in Water or Gas meters, this module facilitates advanced metering features like hassle free remote metering, instantaneous consumption reports and remote detection of fault conditions like leaks or reverse flow, illegal usage and tampering. The RS-SE-401 includes WLAN and higher layer functionality with WPA2 security, IPSec, a network stack that terminates TCP/IP and UDP connections with IPv6 and configuration capability through wireless or UART. The module can provide a battery life of over 10 years with a 2000 mAh battery.



Features

- Compliant to 802.11 b/g and single stream draft 802.11n
- Supports DLMS compliant meter server stack
- 28 dBm Transmit Power and -98 dBm Sensitivity in the most robust mode (1Mbps), along with antenna diversity enables longer range and robust connectivity
- High Multipath tolerance of upto 2 micro-seconds maximum delay spread
- Ultra low power operation, providing over 10-year battery life with 2000 mAh battery
- Supports 802.11s mesh networking
- Automated consumption information for utility companies as well as users. Fully functional software for sensing and telemetry with programmable configurations
- Automatic detection of fault conditions like leaks and reverse flow as well as meter tampering and illegal usage
- Includes all the protocol and configuration functions required for WLAN connectivity in open and WPA2, WMM and WMM-PS secure modes of operation
- Includes an ultra low power microcontroller for applications and network protocol support
- Operates directly off battery voltage (2V – 3.6V)
- Ultra-low power watchdog timer and battery brown-out detection in less than 1uA
- Configuration and Firmware upgrade through wireless and UART interface ; Multiple GPIOs supported for any other interfacing
- Integrated Wireless Frequency reference, low-frequency sleep clock, ultra-low-power shutdown clock and diversity antennas (connector option for external antennas is also available)
- Ad-hoc, infrastructure and low-power peer-to-peer modes for maximum deployment flexibility

Applications

- Water Meters communicating to utility through AMI home gateway
- Gas Meters communicating to utility through AMI home gateway
- Water Meters communicating to back-haul Metro Wi-Fi
- Gas Meters communicating to back-haul Metro Wi-Fi
- Battery operated Wi-Fi sensors with long-range requirement

Specifications

Network Standard Support	IEEE 802.11b/g, draft 802.11n
Interfaces	UART, SPI, GPIO, I2C
Data Rates	802.11n: 6.5, 13, 19.5, 26, 39, 52, 58.5, 65 Mbps 802.11a/g: 6, 9, 12, 18, 24, 36, 48, 54 Mbps 802.11b: 1, 2, 5.5, 11 Mbps
Modulation Techniques	OFDM with BPSK, QPSK, 16-QAM, and 64-QAM 802.11b with CCK and DSSS
Transmit Power +/- 1.5dB	802.11b : 28dBm 802.11g BPSK/QPSK : 28dBm 802.11g 16-QAM : 26dBm 802.11g 64-QAM 2/3 : 25dBm 802.11g 64-QAM 3/4 : 24dBm 802.11n 64-QAM 5/6 : 23dBm
Receiver Sensitivity +/- 1.5dB	802.11b 1Mbps : -98dBm 802.11g 54Mbps : -75dBm 802.11n 65Mbps : -71.5dBm
Wireless Security	802.11i: AES, TKIP, WEP, WPA, and WPA2
802.11n Features	MCS 0-7, STBC, RIFS, Greenfield Protection, A-MPDU, A-MSDU Aggregation with Block-ack, PSMP, MTBA
Network Protocols	TCP, ARP, UDP, IPv6, IPSec
WLAN Functions	Power save modes, Infrastructure, Adhoc and low-power peer-to-peer modes
Debug Interface	JTAG
Meter-Manufacturer Protocol	DLMS server (IEC 62056)
Configuration and Upgrades	UART, Wireless
Operational Temperature	Industrial Grade -40°C to +85°C

RS-SE-401

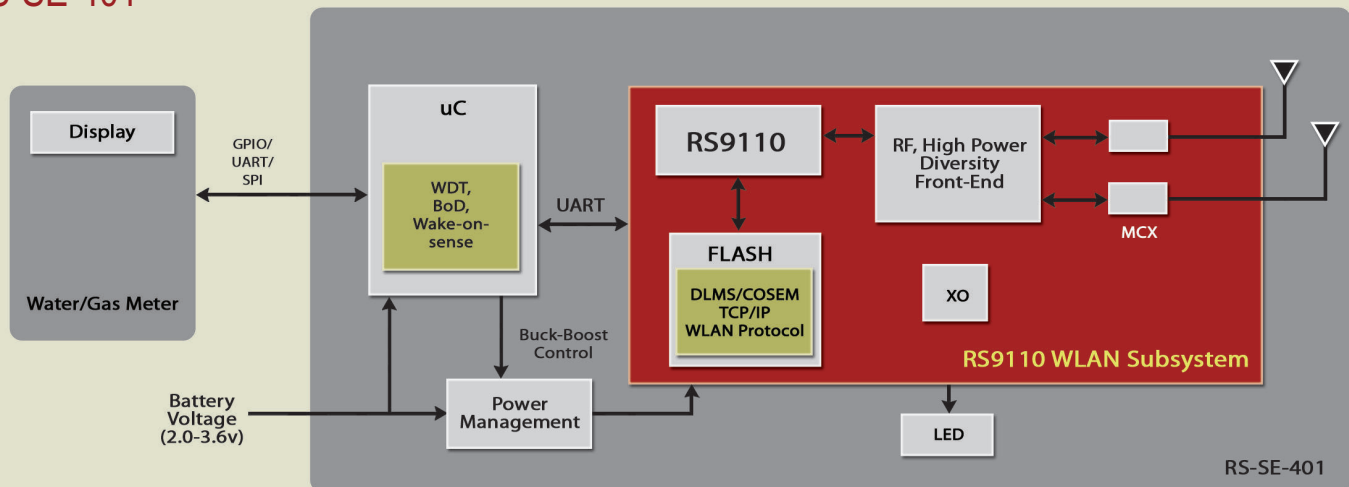

For additional information, please contact Sales at Redpine Signals, Inc.:

Redpine Signals, Inc. • 2107 North First Street • Suite 680 • San Jose, CA 95131

Phone: +1 408 748 3385 • Email: sales@redpinesignals.com

www.redpinesignals.com

Lite-FiTM
REDPINE
Ultra Low Power Wi-FiTM

Redpine Signals, Inc. reserves the right to make changes to the product(s) or information contained herein without notice. No Liability is assumed as a result of their use or application. Redpine, Redpine Signals, the Redpine logo, Driving Wireless Convergence and Lite-Fi are trademarks of Redpine Signals, Inc. All other company names, products and logos are registered trademarks of their respective companies.