

RS9116 PRODUCT BRIEF



Expanding Wireless Horizons

RS9116

IEEE 802.11N SINGLE CHIP SOLUTION

The RS9116 belongs to Redpine Signals' high performance Maxi-Fi™ family's BEAM150 series. It is a small form-factor single-chip solution for Access Points and Client devices as per the IEEE 802.11b/g and draft 802.11n standards (backward compatible with 802.11b/g), supporting data rates as high as 150Mbps. It integrates a Medium Access Layer (MAC), Baseband processor, Radio Frequency (RF) Transceiver, Low Noise Amplifier (LNA) and Power Amplifier functionality into a single chip. The RS9116 is optimized in terms of RBOM cost reduction. Thus, no special external devices are needed and the number of external components is limited to the lowest possible component count. The RBOM is around 25% lower than any existing solution currently on the market. An innovative integrated calibration circuit supports on-the-fly calibration and helps to reduce the manufacturing calibration time to a minimum. Thus, no expensive RF test equipment and no external trimming are necessary. The RS9116 comes in a small footprint PG-VQFN-108 package with a body size of 12mmx12mm supporting SDIO and SPI interfaces.

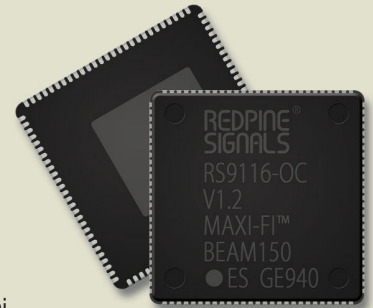

Features

- Single chip 802.11b/g/n transceiver with integrated baseband, MAC, RF, LNA and PA
- Frequency range 2.4-2.497 GHz
- Support of 20 and 40 MHz bandwidth (Autosensing)
- Auto Channel Selection
- Support of Channel 14
- STBC in receive direction
- Short Guard Interval
- Integrated Tx-Balun and Matching network to reduce RBOM and footprint
- Tx-Balun and Matching network to reduce RBOM and footprint
- Header Parsing (IEEE 802.3 to/from IEEE 802.11)
- Integrated calibration circuit for time and cost efficient production testing (no RF test equipment or external trimming)
- A-MPDU Aggregation (up to 65535 octets)
- A-MSDU Aggregation (up to 7935 octets)
- Block Acknowledgement
- Encryption (WEP-64/128, TKIP, CCMP)
- Retransmission of non-acknowledged frames
- On-the-fly trimming with integrated temperature and supply monitoring
- Integrated PLL with output clocks for Ethernet and router devices (25 and 36 or 40 MHz respectively)
- SDIO and SPI interface
- Single 3.3 V supply
- Compliant to European Union Code of Conduct (CoC) requirements
- Very low RBOM
- Small footprint PG-VQFN-108 package (12mm x 12mm)

Applications

- Wireless Routers
- Broadband Access Modems
- Home Gateways
- Integrated Access Devices (IADs)
- High-definition (HD) Video transfers
- Smart Energy Meters
- Laptops
- DVD Players
- Set-top Boxes

Specifications

Network Standard Support	IEEE 802.11b/g, 802.11n, 802.11e, 802.1X, 802.11i, 802.11w, 802.11k, 802.11p
Data Rates	802.11n (20MHz): 6.5, 13, 19.5, 26, 39, 52, 58.5, 65 Mbps 802.11n 40MHz (800ns GI): 13.5, 27, 40.5, 54, 81, 108, 121.5, 135Mbps 802.11n 40MHz (400ns GI): 15, 30, 45, 60, 90, 120, 135, 150 Mbps 802.11a/g: 6, 9, 12, 18, 24, 36, 48, 54 Mbps 802.11b: 1, 2, 5.5, 11 Mbps
Modulation Techniques	OFDM with BPSK, QPSK, 16-QAM, and 64-QAM 802.11b with CCK and DSSS
QoS	WMM and WMM Power Save Support
Wireless Security	802.11i: AES, TKIP, WPA2, WPS, WPSE
802.11n Features	MCS 0-7, STBC, RIFS, Greenfield Preamble, 40MHz BW, SGI A-MPDU, A-MSDU Aggregation with Block-ack, PSMP, MTBAHost
Transmit Power (on-chip PA, after integrated Tx-balun)	17.5dBm for 802.11g 64QAM 20dBm for 802.11b CCK
Receive Sensitivity	-90.5dBm for 11Mbps (802.11b) -76.5dBm for 54Mbps (802.11g) -70.5dBm @ 150Mbps (802.11n)
Interfaces	SDIO v1.2/2.0, SPI
Other Interfaces	JTAG
Certification Support	WiFi (WPA, WPA2, WMM, WMM Power-save, WPS, 11n Draft 2.0)
Supply Voltage	3 – 3.6 V
Operating Temperature	0°C to +85°C
Package	RS9116-QC 108-pin VQFN, 12mm x 12mm

Module Reference Design

A complete module reference design, which integrates the RS9116 with all the other required external components, is available from Redpine Signals, Inc

Software Package

Redpine Signals provides a comprehensive software package that includes complete MAC firmware, reference drivers, manufacturing software and configuration graphical user interface (GUI) for Linux, Windows® Embedded CE, Windows Mobile and Windows XP for Access Point and Client devices. Additional support for host/client communications, information exchange between host and RS9116, WLAN configuration and power management is also available.

RS9116 PROCESSOR SYSTEM DIAGRAM

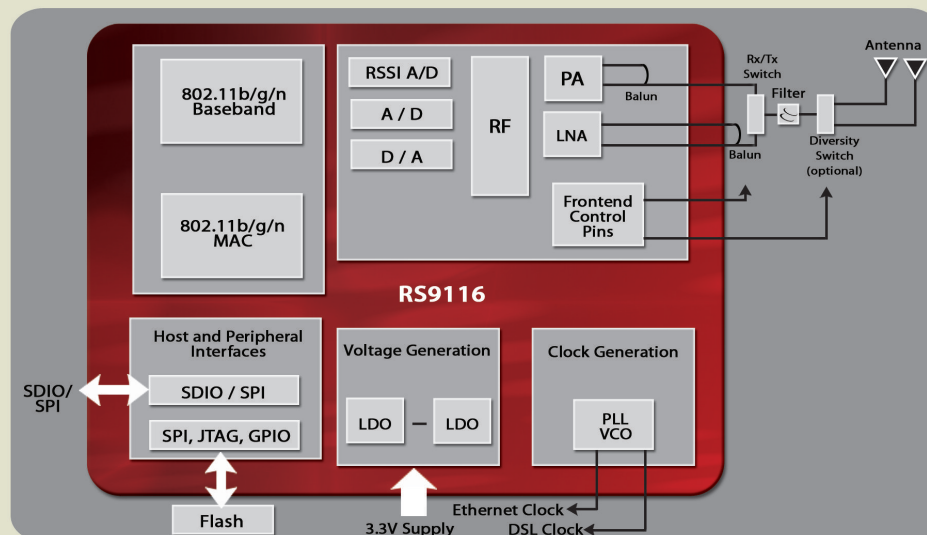

For additional information, please contact Sales at Redpine Signals, Inc.:

Redpine Signals, Inc. • 2107 North First Street • Suite 680 • San Jose, CA 95131
Phone: +1408 748 3385 • Email: sales@redpinesignals.com

www.redpinesignals.com

Redpine Signals, Inc. reserves the right to make changes to the product(s) or information contained herein without notice. Noliability is assumed as a result of their use or application. Redpine, Redpine Signals, the Redpine logo, Expanding Wireless Horizons and Lite-Fi are trademarks of Redpine Signals, Inc. All other company names, products and logos are registered trademarks of their respective companies.

© Copyright 2008 Redpine Signals, Inc. All Rights Reserved

Maxi-FiTM
REDPINE

High Performance BEAM150 Wi-Fi